



2024+ TOYOTA BOLT-ON PORTALS

FEATURES AND BENEFITS OVERVIEW

WHAT ARE PORTALS?

74WELD Portals are gear boxes that give you

- YOUR LIFT
- YOUR RE-GEAR
- YOUR GROUND CLEARANCE

All in one **BOLT-ON** package



3.88 INCHES OF GROUND CLEARANCE

- Larger ground clearance gain than going from a 33 to a 40 inch tire
- Allows for optimized suspension geometry and superior ride quality

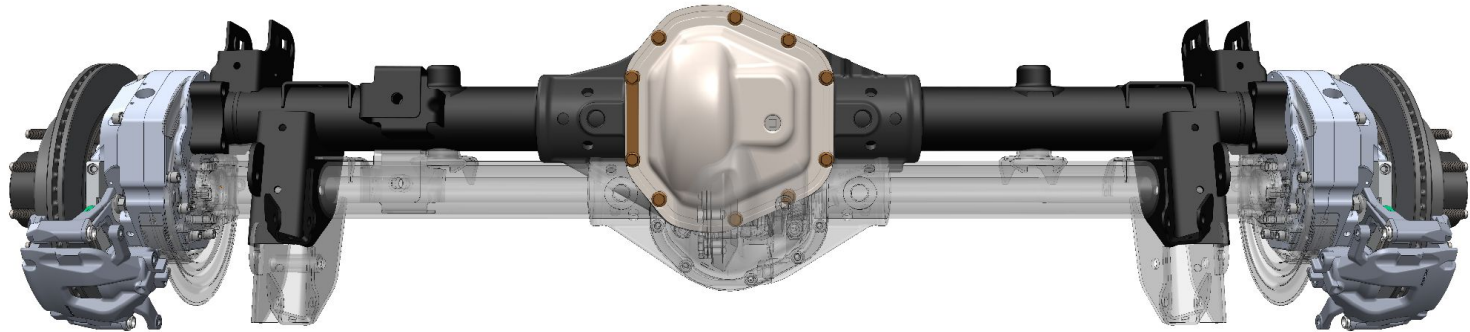

22% GEAR REDUCTION AT THE HUB

- INCREASED TORQUE OUTPUT
- LESS STRESS ON UPSTREAM COMPONENTS

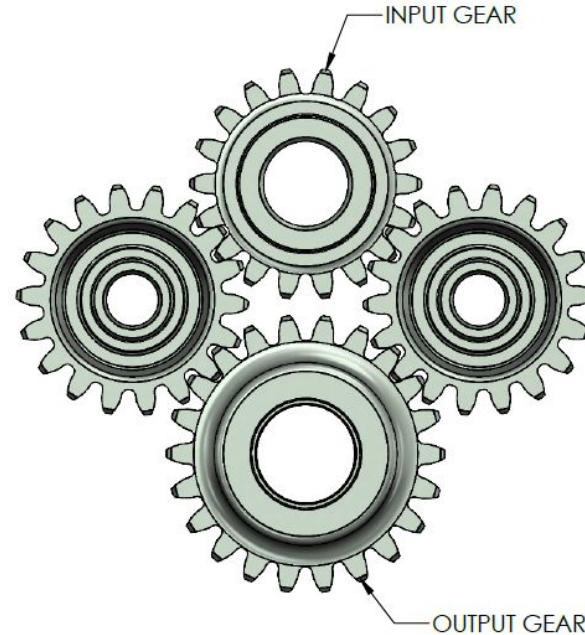

35 SPLINE FINAL DRIVE

- REPLACES YOUR FACTORY WHEEL ENDS WITH **ABS COMPATIBLE** 35 SPLINE UNIT BEARINGS
- CONVERTS YOUR STOCK 30 SPLINE FINAL DRIVE SHAFTS WITH 35 SPLINE AT ALL FOUR CORNERS

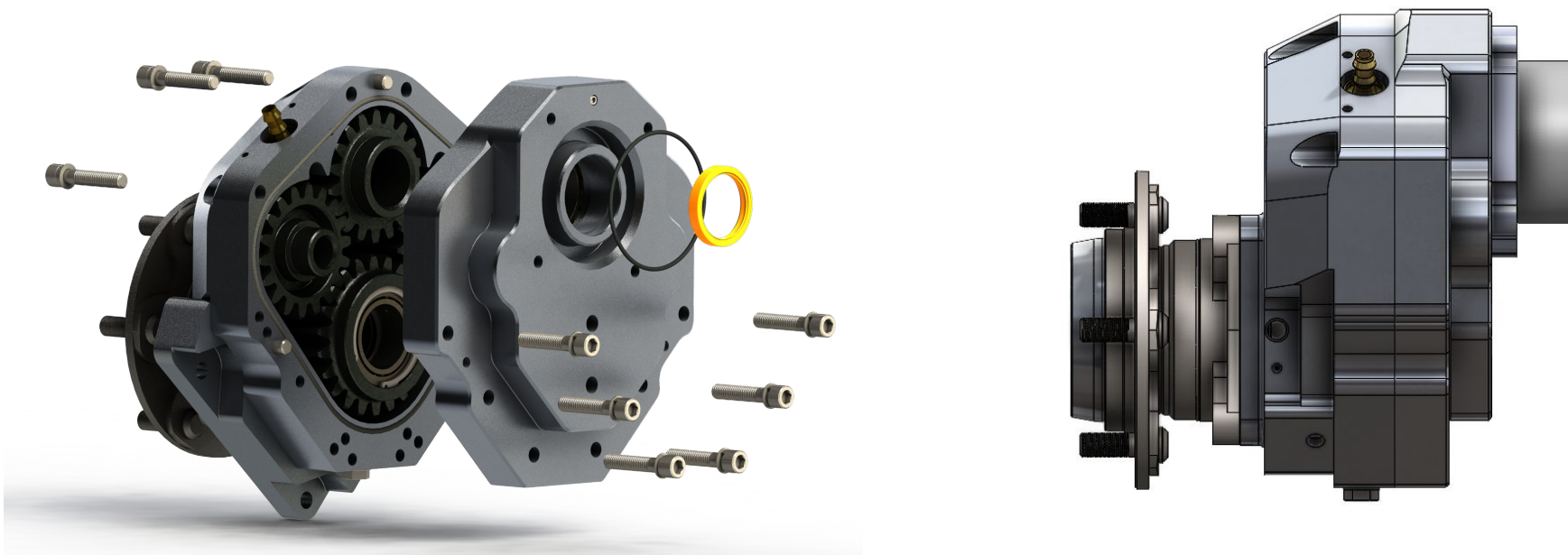

FAQ - GENERAL

Question: Is this a bolt on product?

Answer: Yes it is 100% bolt on

Question: What is the warranty?

Answer: We offer a limited lifetime warranty on the knuckle and housing.

Question: Is this compatible with my factory ABS?

Answer: Yes, all factory ABS functionality is retained. You will not have a light on your dash

Question: What kind of maintenance is required?

Answer: Oil changes are recommended every 3,000 miles

Question: Do I keep my factory unit bearing?

Answer: No. We upgrade you to 35 spline unit bearings

Question: What vehicles are these portals compatible with?

Answer: 2024+ Tacoma

2024+ Land Cruiser LC250

2025+ 4 Runner

2022+ Tundra

2022+ Sequoia

2024+ Lexus GX550

Question: Will this widen my vehicle?

Answer: Yes the portal adds 2.75" per side to the factory axle width

Question: What is the gear reduction?

Answer: The portal is a 1.22:1 gear reduction

Question: Will I have a problem at high speeds?

Answer: No. These are designed to be able to spin faster than your Jeep can ever go.

Question: Do I need special wheels?

Answer: No, you can use any 6x5.5 wheel but we strongly recommend a 5.5"-6.5" offset wheel commonly made by Method, KMC, Raceline, Dirtylyfe, Vision, etc.

FAQ - SUSPENSION & DRIVETRAIN

Question: How much lift does the portal give me?

Answer: 3.88". This means your entire vehicle is lifted giving you unparalleled ground clearance.

Question: Do I need new axle shafts?

Answer: The front axle shafts are retained and bolt in. We convert your rear semi float axle to a full float and provide you with 4340 axle shafts.

Question: What spline are the portals?

Answer: All final drive in our portals is 1.5" 35 spline. The rear upper gears are also 35 spline allowing you to run larger rear axle shafts. We do this so down the road if you want to upgrade your stock axle to a Dana 60 all you will need is new axle shafts to go full 35 spline.

Question: Is this a strength upgrade over stock?

Answer: Yes. On top of the reduced torque due to the gear reduction (22%) we upgrade your final drive to 1.5" 35 spline domestic 4340 heat treated axles.

Question: What does this do to the rest of my drivetrain?

Answer: Our portal reduces torque on the rest of your drivetrain. All of your axles, driveshafts, and drivetrain see 22% less torque making everything stronger!

Question: How do the portals affect scrub?

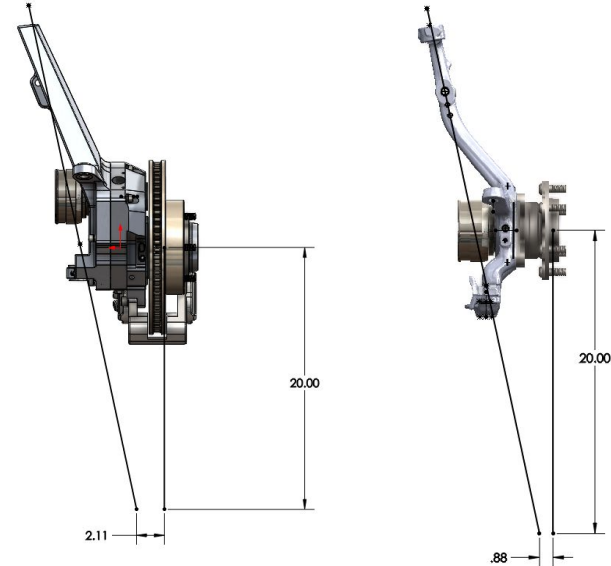

74WELD PORTAL
40 INCH TIRE
6.00" BACKSPACE WHEEL

STOCK AXLE
40 INCH TIRE
4.50" BACKSPACE WHEEL

**2023 TACOMA NUMBERS SHOWN

FAQ - INSTALLATION

Question: What is included in the kit

Answer: 4 portals, new front rotors, upgraded 2-piece rear rotors, and 4340 heat treated full float shafts. We provide you with everything you need to bolt them on.

Question: How difficult is the install?

Answer: If you are comfortable changing out a ball joint on your front end you can install our portals. You will be taking apart your front end as well as removing your rear axle shafts. If this is intimidating, we can point you in the direction of an approved installation shop.

FAQ - DURABILITY

Question: Are my factory ball joints strong enough for portals?

Answer: As with any big tire application, upgraded ball joints are recommended for increased longevity

Question: Is my stock axle housing strong enough for portals?

Answer: As with any big tire application, the factory axle housing tubes are a weak point. An aftermarket housing or truss of the factory is recommended.

Question: Are these portals strong enough for my hemi swap?

Answer: There is a 10% difference in size between this gear set and our racing platform which is proven in 1000+ HP Trophy Trucks and Ultra4 vehicles.

Question: Where is this product made?

Answer: This is a USA made product!