

74W-SR-BRONCO-HOUSING-3.0
STEERING RACK, FORD BRONCO, HOSS 3.0, HOUSING
REVISION: -

	PART NUMBER	DESCRIPTION	MAKE/BUY	MFG	QTY
601	74W-SR-U725-CASE-PINION	CASE, PINION, BRONCO STEERING RACK	MAKE	74WELD	1
602	74W-SR-U725-CASE-MOTOR	CASE, MOTOR, BRONCO STEERING RACK	MAKE	74WELD	1
603	74W-SR-U725-TUBE-V2	TUBE, BRONCO STEERING RACK	MAKE	74WELD	1
604	74W-SR-U725-TUBE-FLANGE	FLANGE, TUBE, BRONCO STEERING RACK	MAKE	74WELD	1
605	74W-SR-U725-CASE-ENDCAP	CASE, END CAP, BRONCO STEERING RACK	MAKE	74WELD	1
606	74W-SR-U725-PLUG-PINION	PLUG, PINION, BRONCO STEERING RACK	MAKE	74WELD	1
607	74W-SR-U725-BSHNG-PINION	BUSHING, PINION SIDE, BRONCO STEERING RACK	MAKE	74WELD	1
608	74W-SR-U725-BSHNG-CAP	BUSHING, CAP SIDE, BRONCO STEERING RACK	MAKE	74WELD	1
609	74W-SR-U725-COVER-PINION	COVER, PINION CAVITY, BRONCO STEERING RACK	MAKE	74WELD	1
620	HW-620	9452K79 - O-RING, DASH 025, BUNA N	BUY	MCMaster	1
621	HW-621	9452K125 - O-RING, DASH 037, BUNA N	BUY	MCMaster	1
622	HW-622	9452K133 - O-RING, DASH 044, BUNA N	BUY	MCMaster	1
623	HW-623	9452K315 - O-RING, DASH 050, BUNA N	BUY	MCMaster	1
624	HW-624	9452K123 - O-RING, DASH 035, BUNA N	BUY	MCMaster	2
625	HW-625	9452K152 - O-RING, DASH 145, BUNA N	BUY	MCMaster	1
626	HW-626	90442A668 - INVERTED EXTERNAL RETAINING RING, 1.500 ID	BUY	MCMaster	2
627	HW-627	98381A471 - DOWEL, STEEL, 1/8" DIA, 1/2" LG	BUY	MCMaster	2
628	HW-628	98381A537 - DOWEL, STEEL, 1/4" DIA, 1/2" LG	BUY	MCMaster	7
629	HW-629	90128A288 - SCREW, SKT HD CAP, M10X1.5, 35MM LG, ALLOY STEEL, ZINC PLATED	BUY	MCMaster	3
630	HW-630	93837A150 - LOCK WASHER, M10, ZINC PLATED STEEL	BUY	MCMaster	3
631	HW-631	94645A220 - NUT, NYLOCK, M10X1.5	BUY	MCMaster	1
632	HW-632	90128A266 - SCREW, SKT HD CAP, M6 X 1, 30MM LG, ALLOY STEEL, ZINC PLATED	BUY	MCMaster	1
633	HW-633	91202A234 - LOCK WASHER, M6, ZINC PLATED STEEL	BUY	MCMaster	1
634	HW-634	54225K217 - HOSE CLAMP, 5/16" WIDE, 2 7/16 - 3 7/32 DIA	BUY	MCMaster	2
508	HW-508	8863T15 - P CLAMP, 9/32 HOLE, 5/8 DIA	BUY	MCMaster	1
635	HW-635	90128A277 - SCREW, SKT HD CAP, M8 X 1.25 X 35 LG, ALLOY STEEL, ZINC PLATE	BUY	MCMaster	6
636	HW-636	90128A274 - SCREW, SKT HD CAP, M8 X 1.25 X 20 LG, ALLOY STEEL, ZINC PLATE	BUY	MCMaster	6

8 7 6 5 4 3 2 1

THIS DRAWING CONTROLS THE FOLLOWING ASSEMBLIES
74W-SR-BRONCO-HOUSING-3.0-74WELD
 3.0 RACK HOUSING, FINAL ASSEMBLY PERFORMED BY 74WELD
74W-SR-BRONCO-HOUSING-3.0-DEALER
 3.0 RACK HOUSING, FINAL ASSEMBLY PERFORMED BY CUSTOMER

REVISIONS				
ZONE	REV.	DESCRIPTION OF CHANGE	DATE	DRAWN
	-	PRODUCTION RELEASE	6/13/23	BES

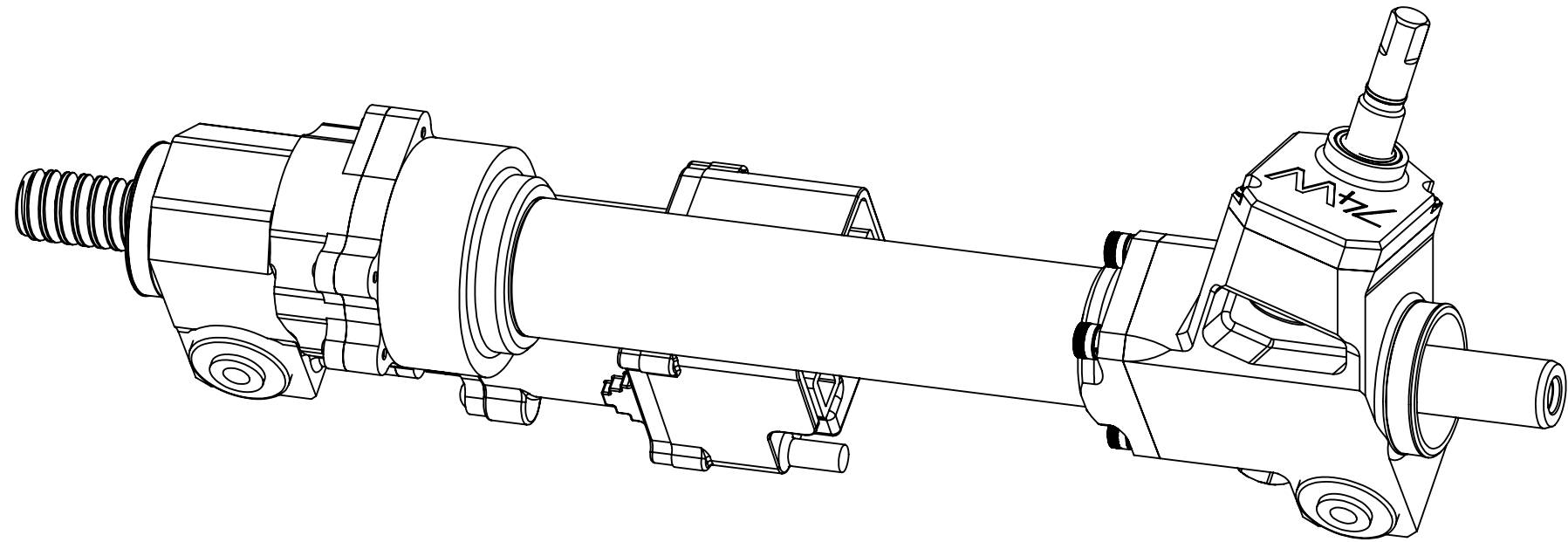

D
C
B
A

D
C
B
A

THIRD ANGLE PROJECTION		UNLESS OTHERWISE SPECIFIED:		NAME	DATE
		DIMENSIONS ARE IN INCHES TOLERANCES: FRACTIONAL ± ANGULAR: MACH ±.5 BEND ±1 .XX ±.03 .XXX ±.010		DRAWN	BES 6/13/23
				CHECKED	XXX XX/XX/XXXX
PROPRIETARY AND CONFIDENTIAL THE INFORMATION CONTAINED IN THIS DRAWING IS THE SOLE PROPERTY OF 74 WELD INC. ANY REPRODUCTION IN PART OR AS A WHOLE WITHOUT THE WRITTEN PERMISSION OF 74 WELD INC. IS PROHIBITED.		INTERPRET GEOMETRIC TOLERANCING PER: ASME Y14.5 MATERIAL SEE BOM FINISH NA		ENG APPR.	XXX XX/XX/XXXX
				MFG APPR.	XXX XX/XX/XXXX
				Q.A.	XXX XX/XX/XXXX
NEXT ASSY	USED ON	COMMENTS:			
APPLICATION		DO NOT SCALE DRAWING			

74WELD

TITLE:
 STEERING RACK, FORD BRONCO,
 HOSS 3.0, HOUSING

SIZE	DWG. NO.	REV
B	74W-SR-BRONCO-HOUSING-3.0	-

SCALE: 1:3 WEIGHT: SHEET 1 OF 10

8 7 6 5 4 3 2 1

TO BE COMPLETED BY 74WELD

D

D

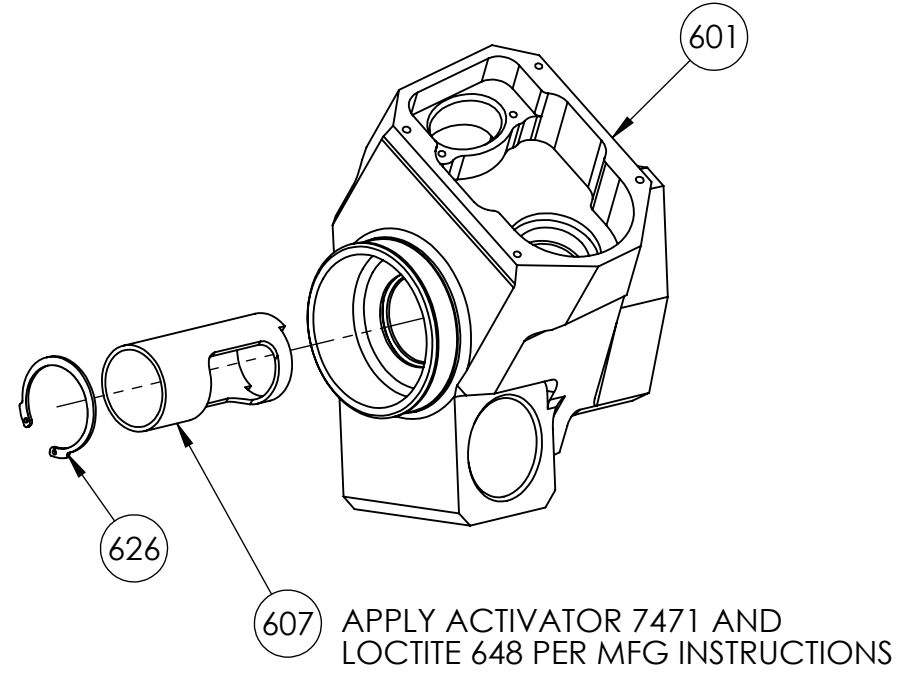
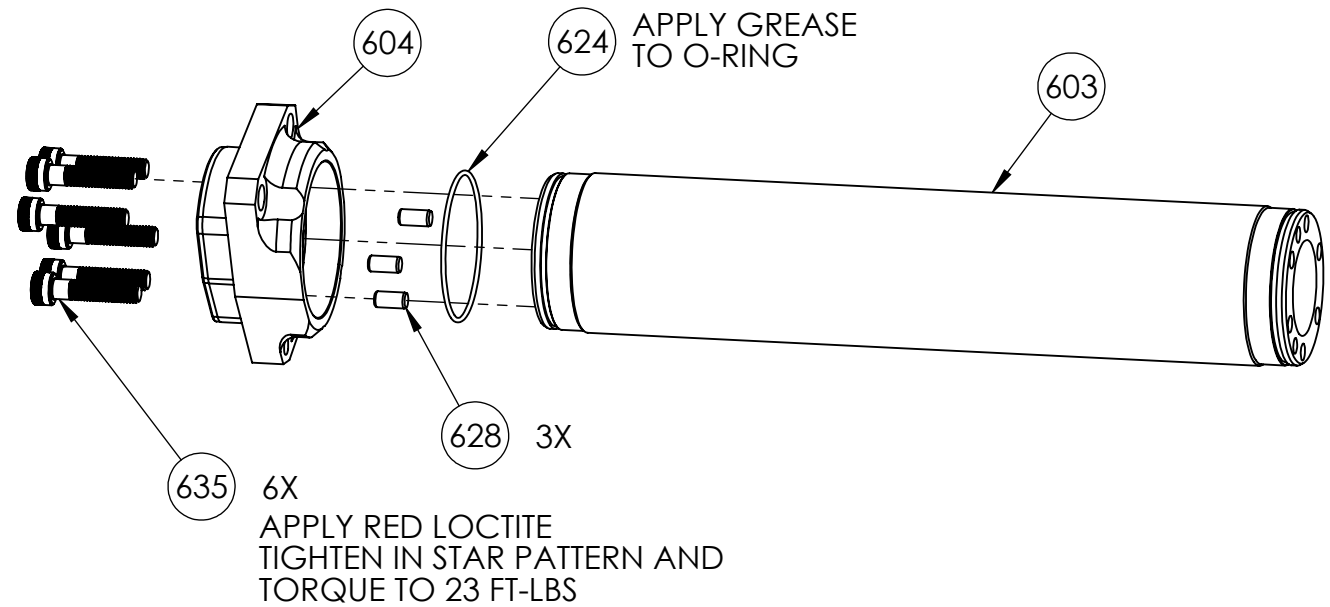

C

C

B

B

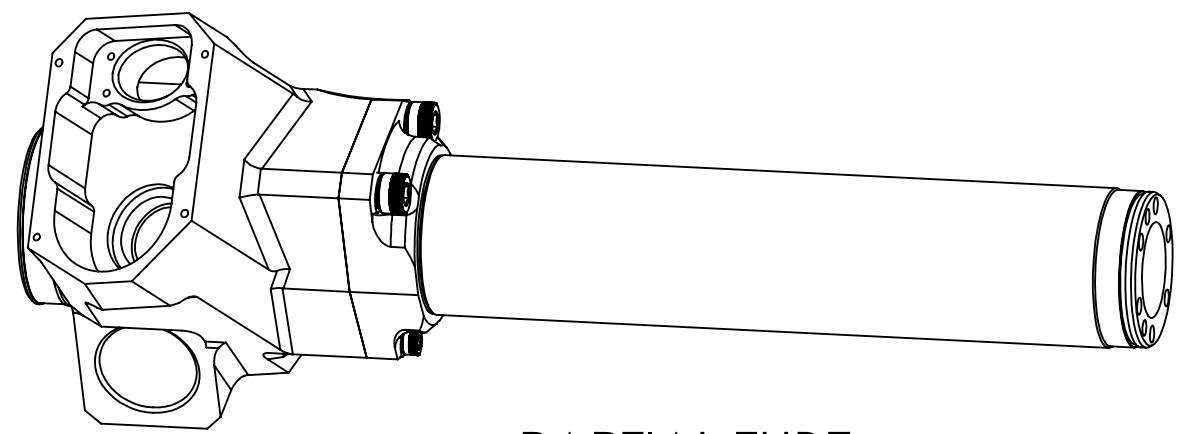
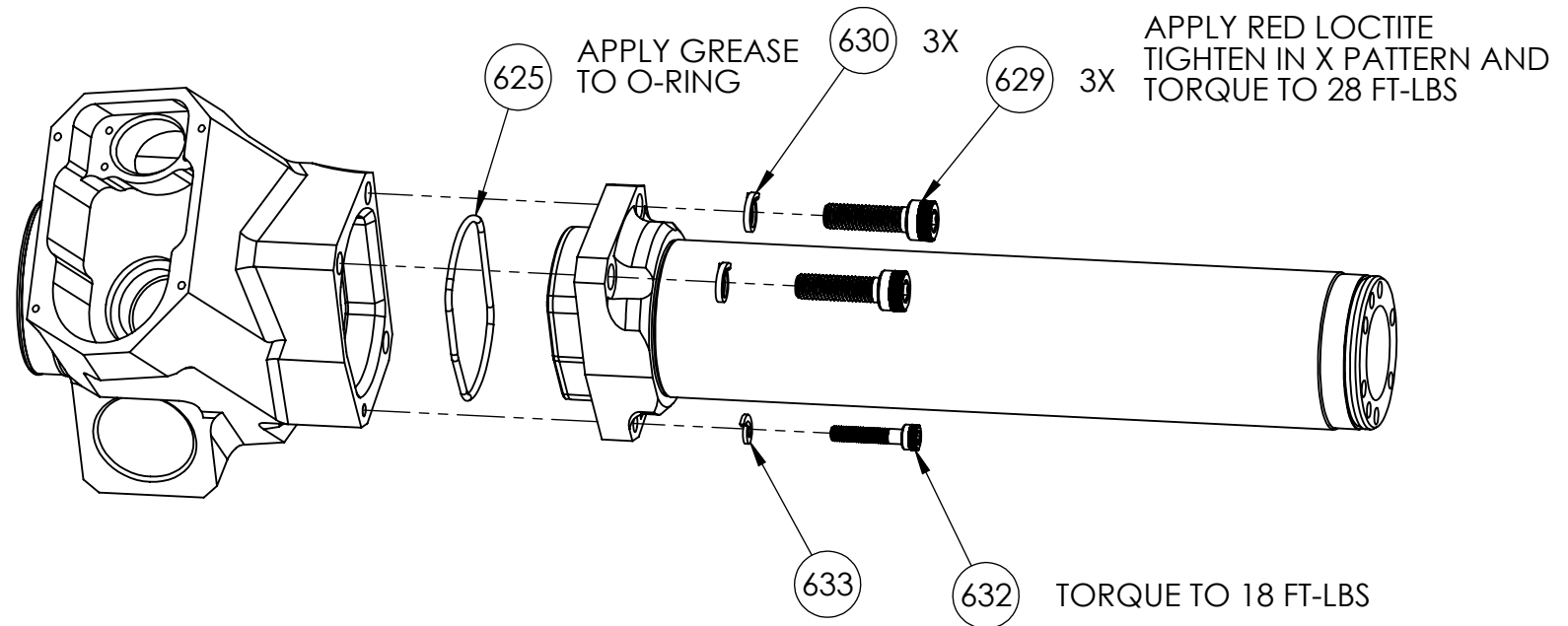

PARTIAL TUBE
COMMON TO 2.0 & 3.0 RACKS

A

A

PARTIAL TUBE ASSEMBLY

74WELD		
SIZE B	DWG. NO. 74W-SR-BRONCO- HOUSING-3.0	REV -
SCALE: 1:3	WEIGHT:	SHEET 2 OF 10

TO BE COMPLETED BY 74WELD

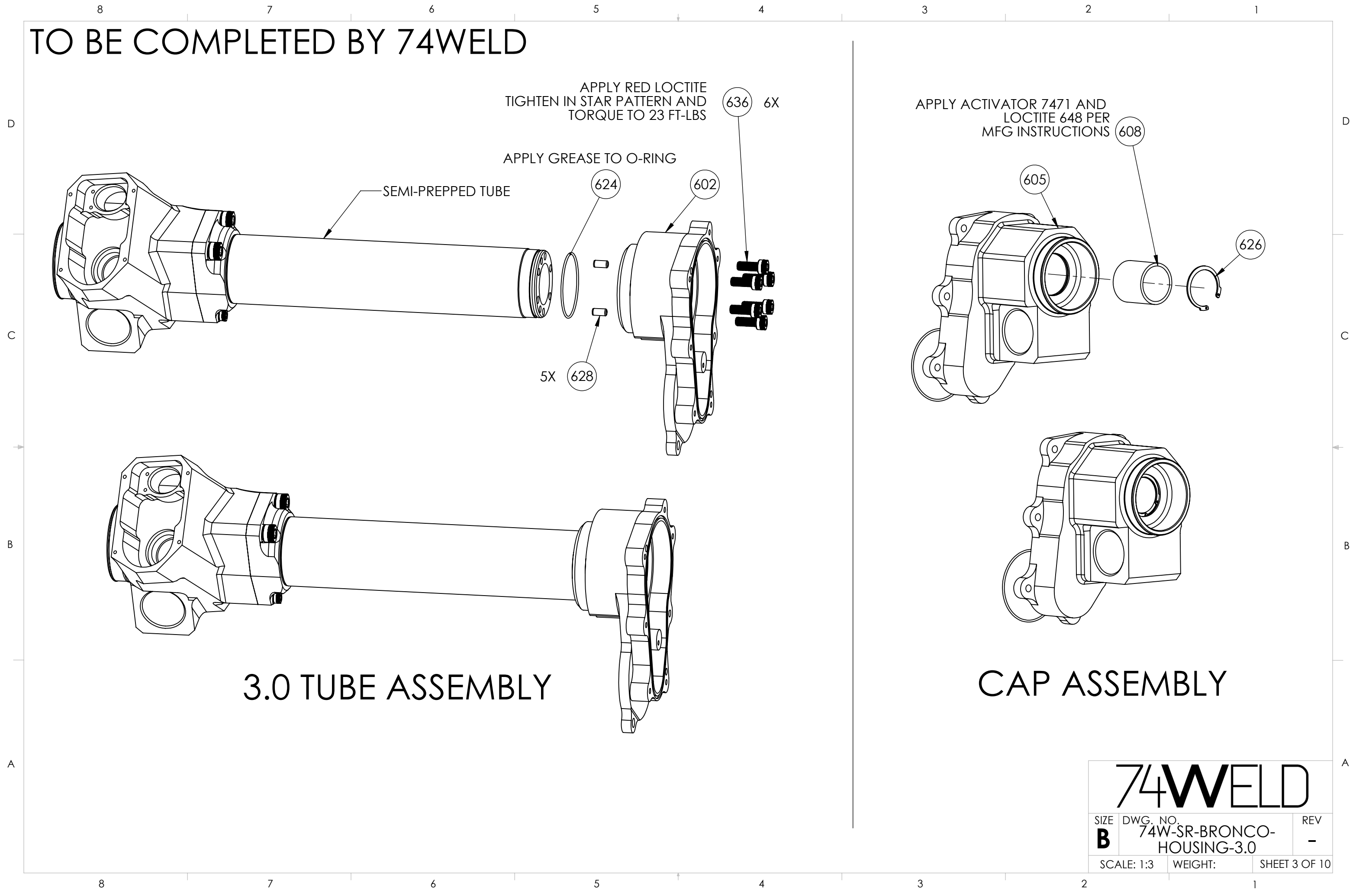

APPLY RED LOCTITE
TIGHTEN IN STAR PATTERN AND
TORQUE TO 23 FT-LBS

APPLY GREASE TO O-RING

SEMI-PREPARED TUBE

APPLY ACTIVATOR 7471 AND
LOCTITE 648 PER
MFG INSTRUCTIONS

3.0 TUBE ASSEMBLY

CAP ASSEMBLY

74WELD		
SIZE B	DWG. NO. 74W-SR-BRONCO- HOUSING-3.0	REV -
SCALE: 1:3	WEIGHT:	SHEET 3 OF 10

74W-SR-BRONCO-HOUSING-3.0-74WELD

(ASSEMBLED AT 74WELD)

GATHER FOLLOWING PARTS AND PROCEED WITH SHEETS 5-10

74W-SR-BRONCO-HOUSING-3.0-DEALER

(ASSEMBLED BY CUSTOMER)

BAG AND TAG FOLLOWING PARTS FOR SHIPMENT

CUSTOMER TO PERFORM INSTALLATION IN SHEETS 5-10

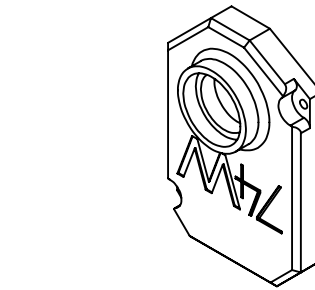
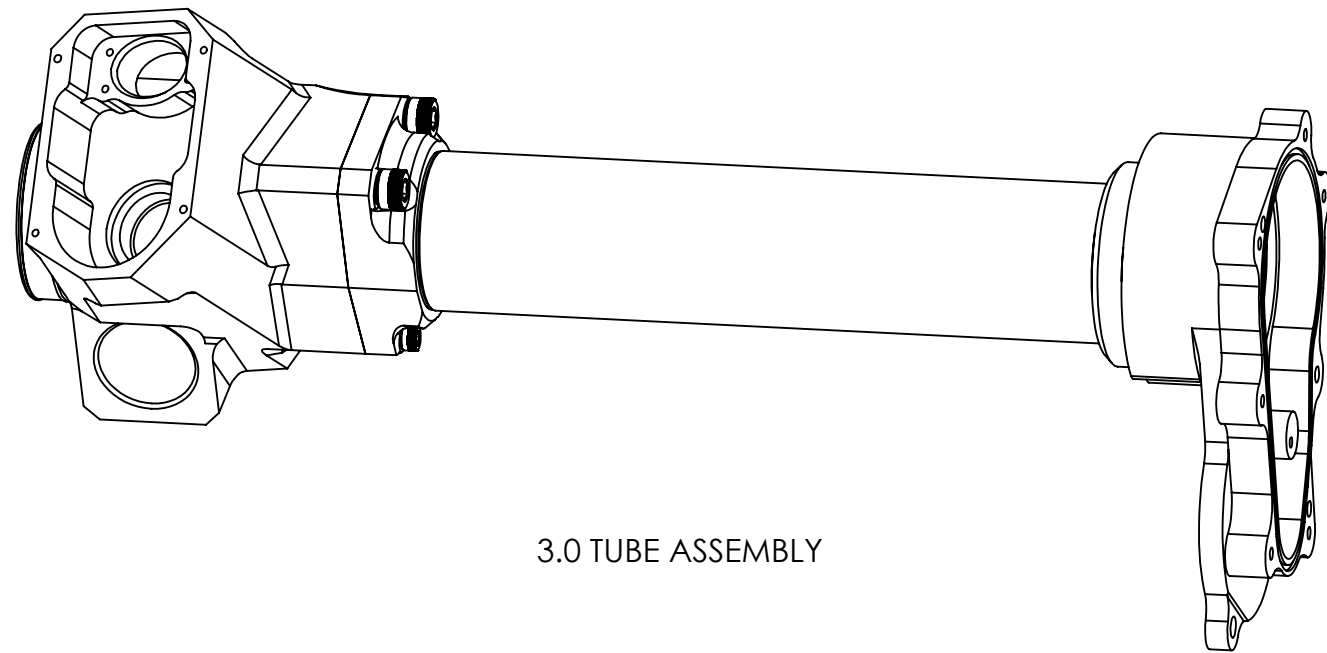

ITEM 609
74W-SR-U725-COVER-PINION
QTY (1)



ITEM 606
74W-SR-U725-PLUG-PINION
QTY (1)

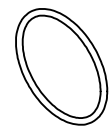

ITEM 620
O-RING
QTY (1)

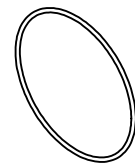

ITEM 621
O-RING
QTY (1)

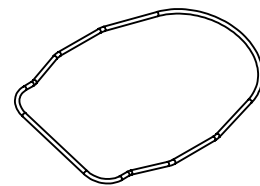

ITEM 622
O-RING
QTY (1)

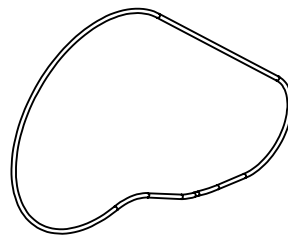

ITEM 623
O-RING
QTY (1)



ITEM 627
1/8" DOWEL PIN
QTY (2)

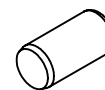

ITEM 628
1/4" DOWEL PIN
QTY (2)



ITEM 631
LOCKNUT
QTY (1)



ITEM 508
P-CLAMP
QTY (1)

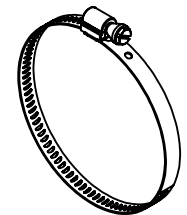

ITEM 634
HOSE CLAMP
QTY (2)

74WELD

SIZE	DWG. NO.	REV
B	74W-SR-BRONCO-HOUSING-3.0	-
SCALE: 1:3	WEIGHT:	SHEET 4 OF 10

8 7 6 5 4 3 2 1

PRIOR TO DISASSEMBLY, ORIENT PINION WITH SCALLOP FACING FORWARD AND MEASURE DISTANCE FROM RACK HOUSING TO RACK BAR. THIS DIMENSION WILL BE USED LATER

REMOVE BOOTS AND TIE RODS. DURING TIE ROD REMOVAL, SUPPORT RACK BAR USING OPEN ENDED WRENCH ON RACK TEETH

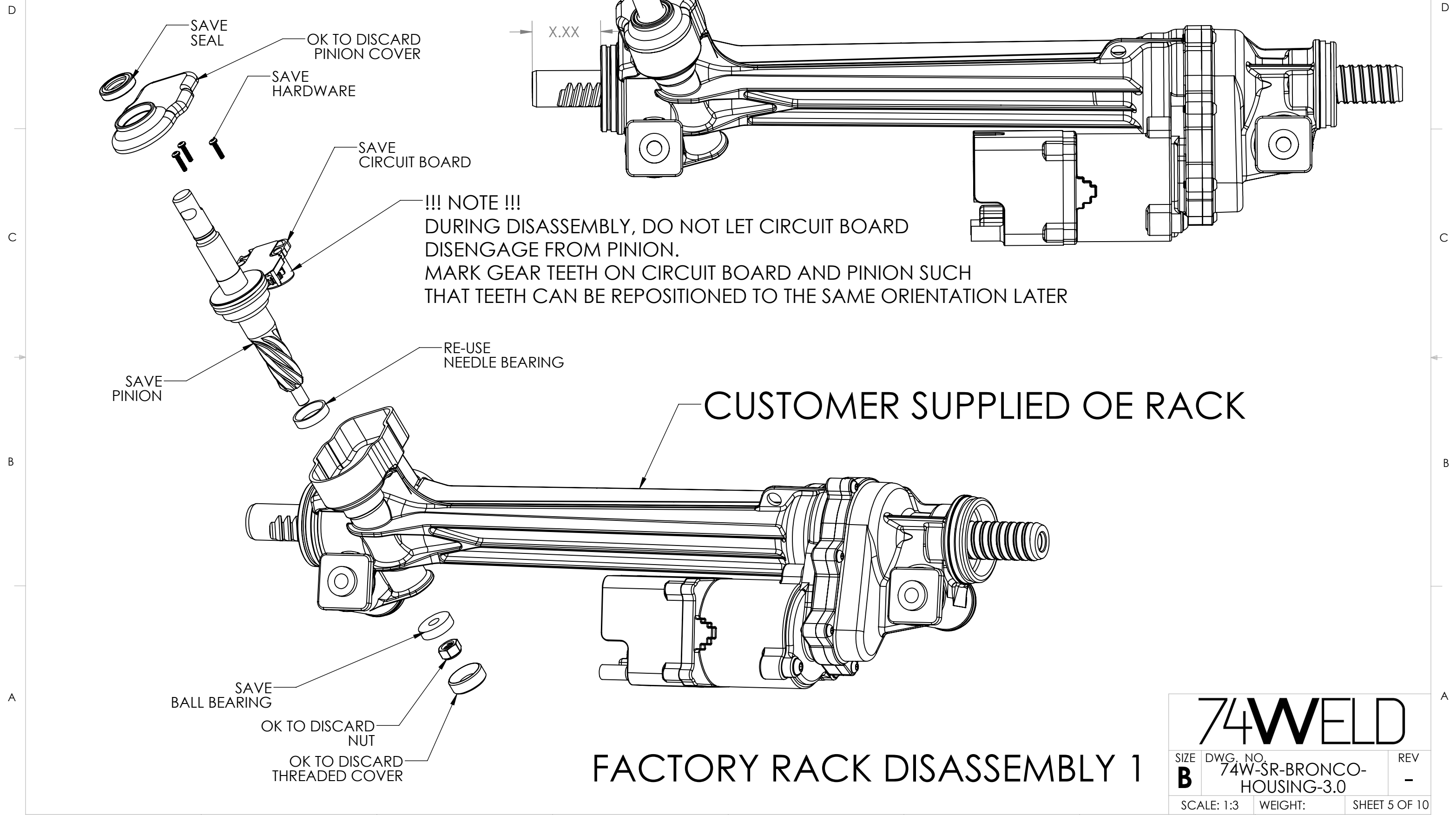

!!! NOTE !!!
DURING DISASSEMBLY, DO NOT LET CIRCUIT BOARD DISENGAGE FROM PINION.
MARK GEAR TEETH ON CIRCUIT BOARD AND PINION SUCH THAT TEETH CAN BE REPOSITIONED TO THE SAME ORIENTATION LATER

CUSTOMER SUPPLIED OE RACK

FACTORY RACK DISASSEMBLY 1

74WELD

SIZE B	DWG. NO. 74W-SR-BRONCO-HOUSING-3.0	REV -
SCALE: 1:3	WEIGHT:	SHEET 5 OF 10

8 7 6 5 4 3 2 1

8 7 6 5 4 3 2 1

D

D

C

C

B

B

A

A

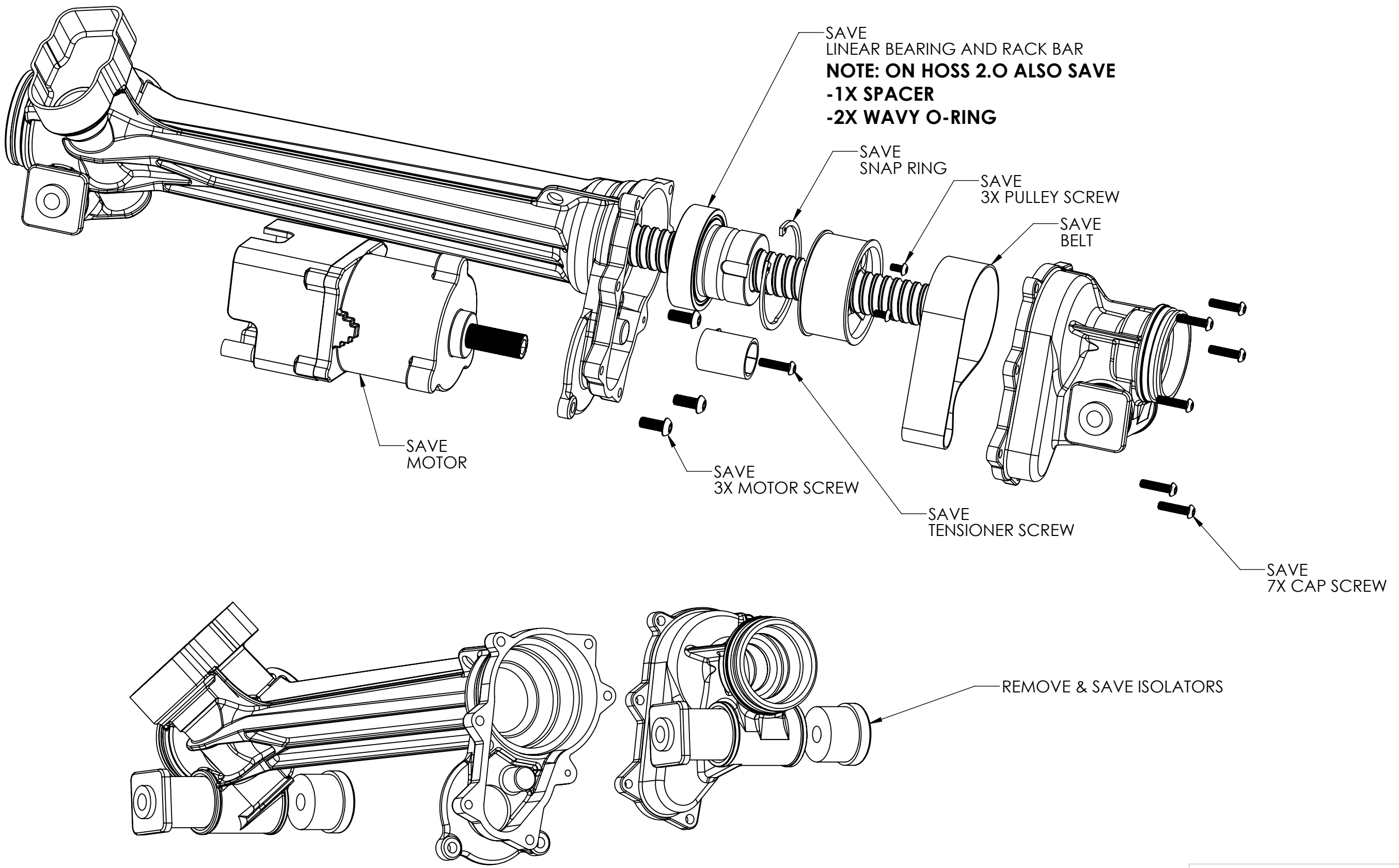

FACTORY RACK DISASSEMBLY 2

74WELD		
SIZE B	DWG. NO. 74W-SR-BRONCO- HOUSING-3.0	REV -
SCALE: 1:3	WEIGHT:	SHEET 6 OF 10

8 7 6 5 4 3 2 1

8 7 6 5 4 3 2 1

D

D

C

C

B

B

A

A

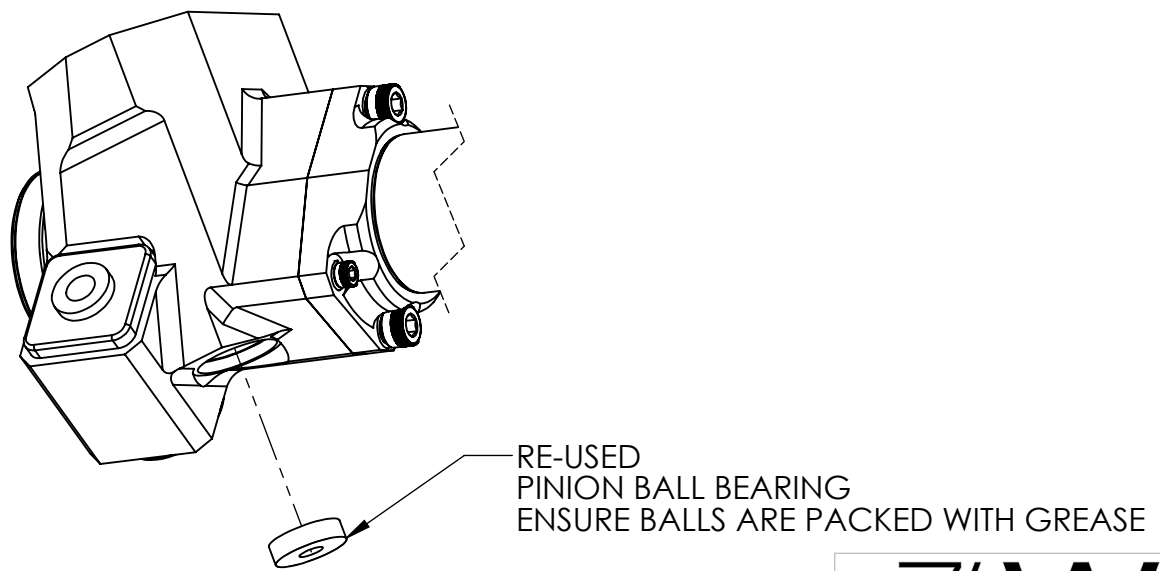
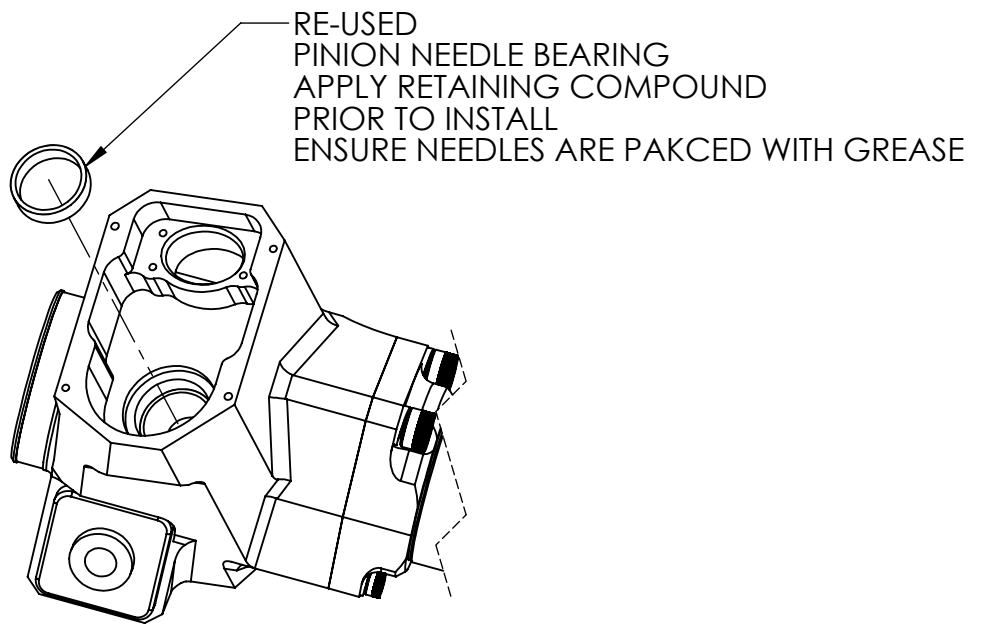
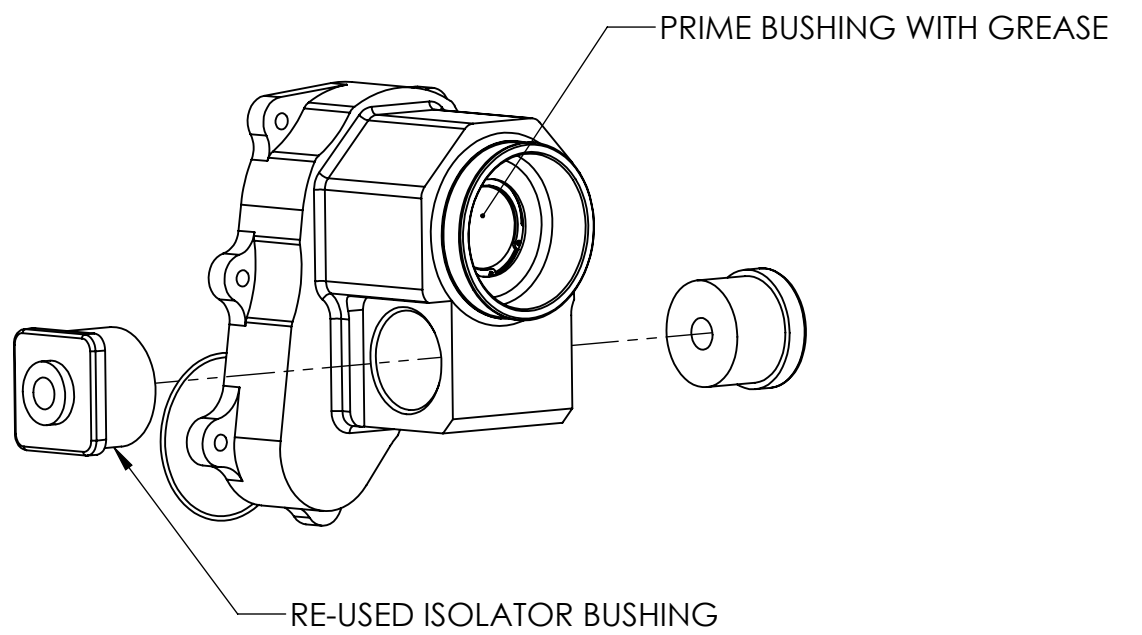
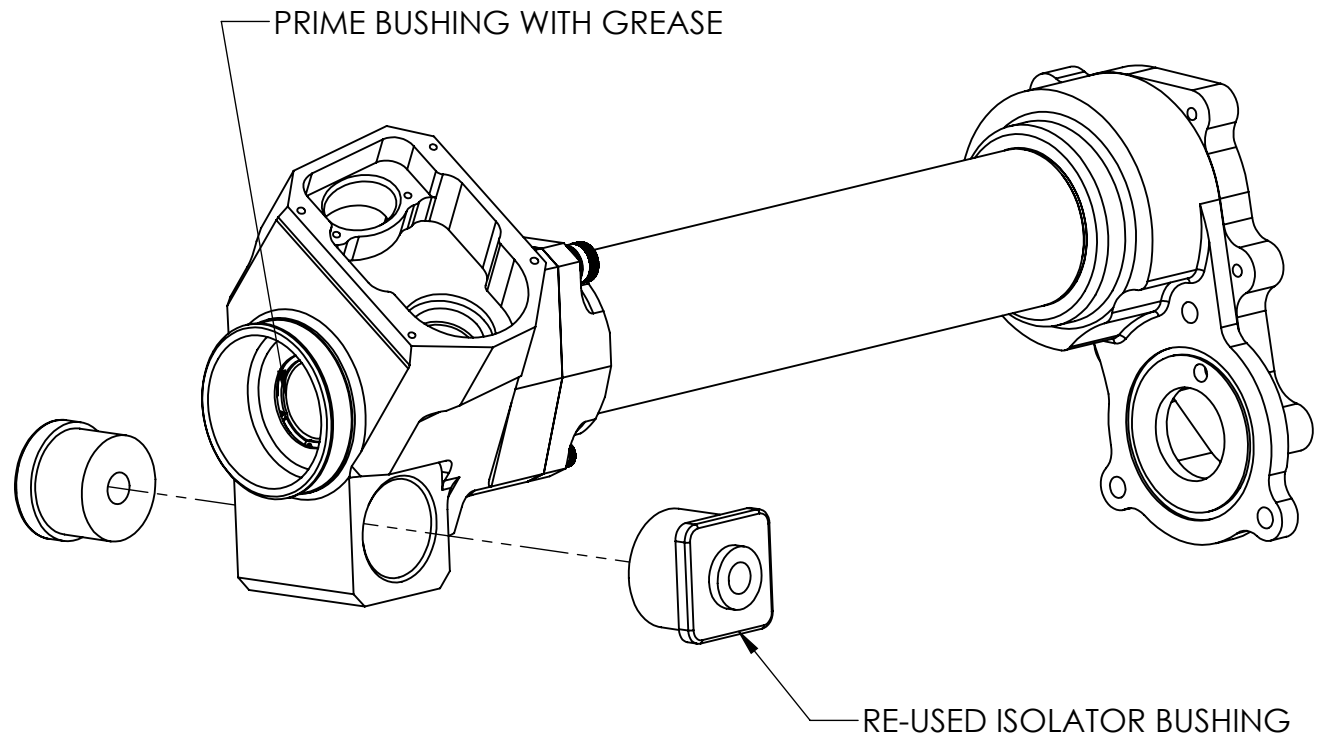

PRESS OPERATIONS

74WELD

SIZE	DWG. NO.	REV
B	74W-SR-BRONCO-HOUSING-3.0	-

SCALE: 1:3	WEIGHT:	SHEET 7 OF 10
------------	---------	---------------

8 7 6 5 4 3 2 1

RACK & PINION SETUP

!!! NOTE !!!
LINE UP GEAR TEETH ON CIRCUIT BOARD AND PINION ACCORDING TO MARKS MADE DURING DISASSEMBLY

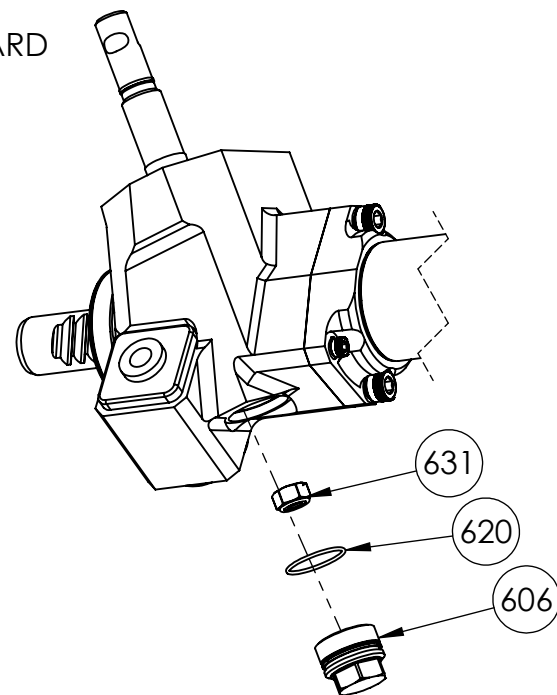
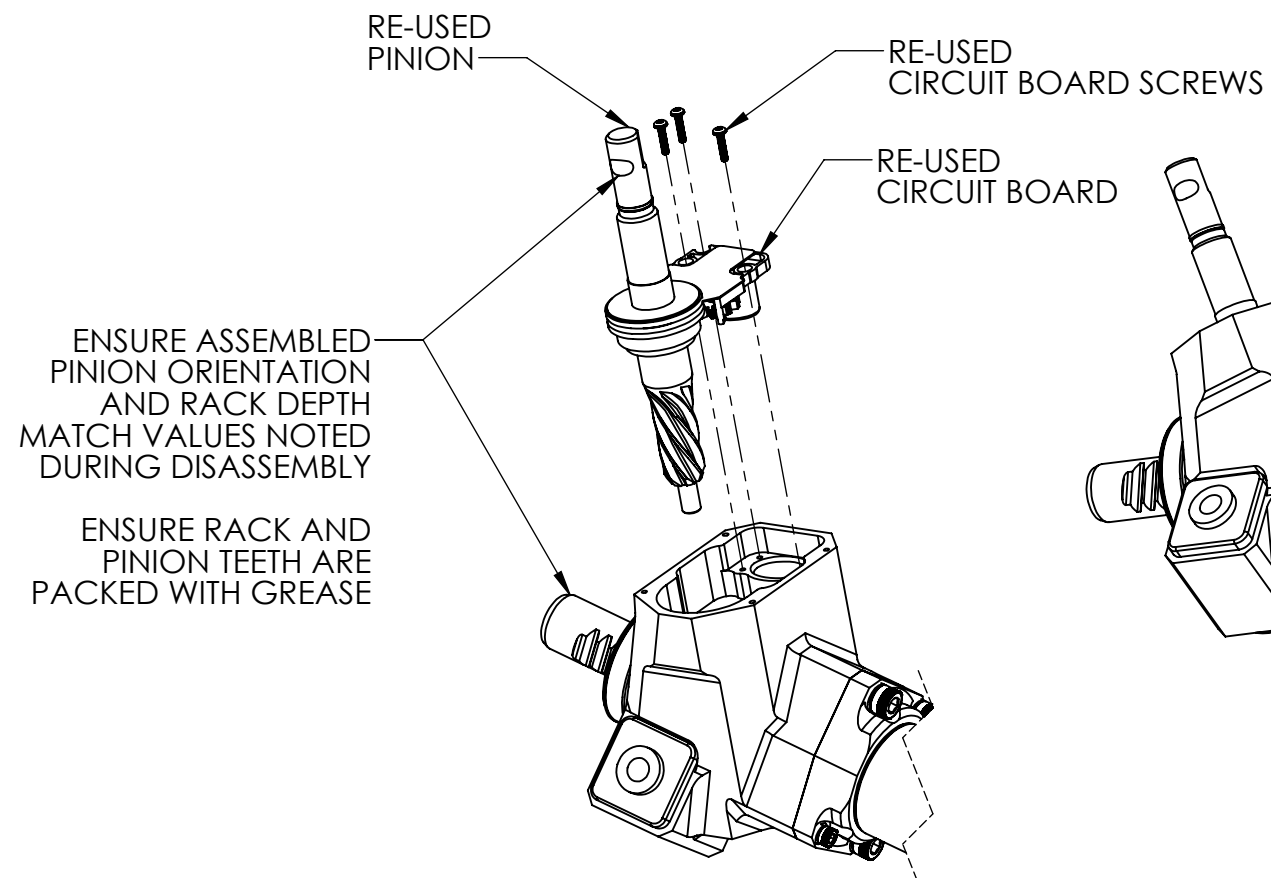
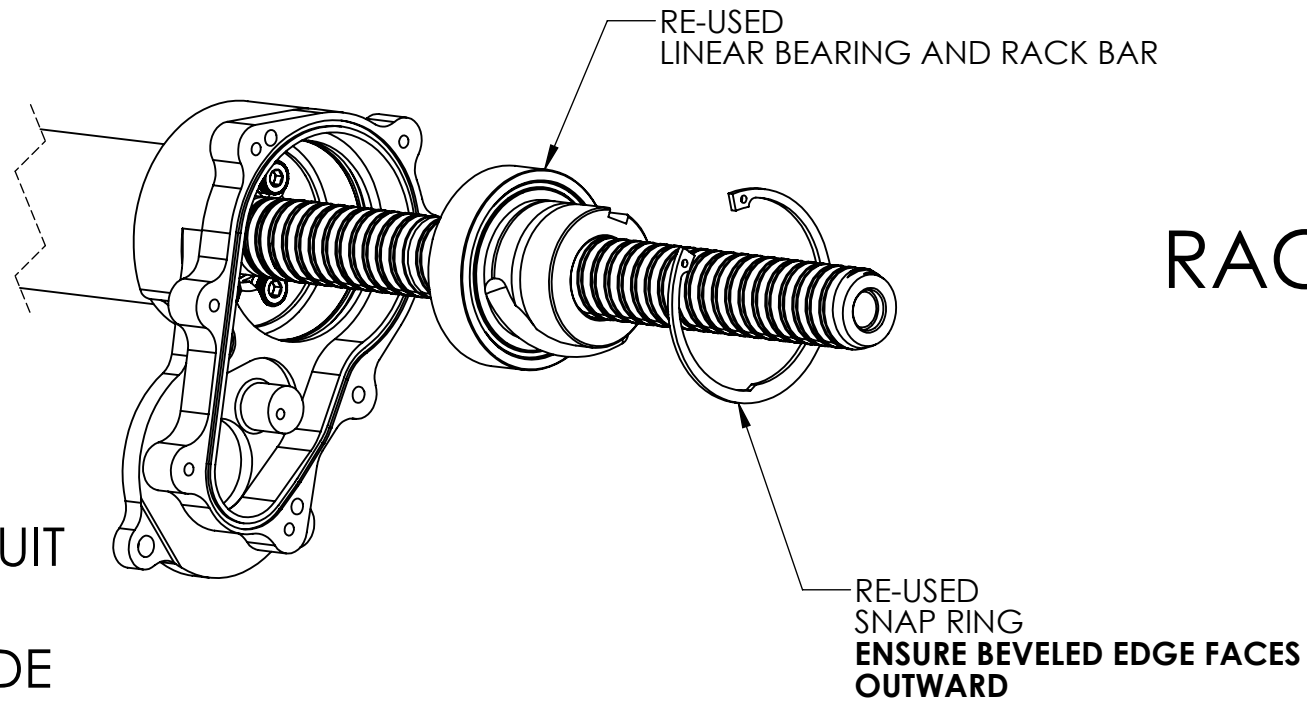

!!! NOTE !!!
DO NOT OPERATE RACK WITHOUT PINION PLUG INSTALLED

APPLY LOCTITE AND TORQURE TO 30 FT-LBS

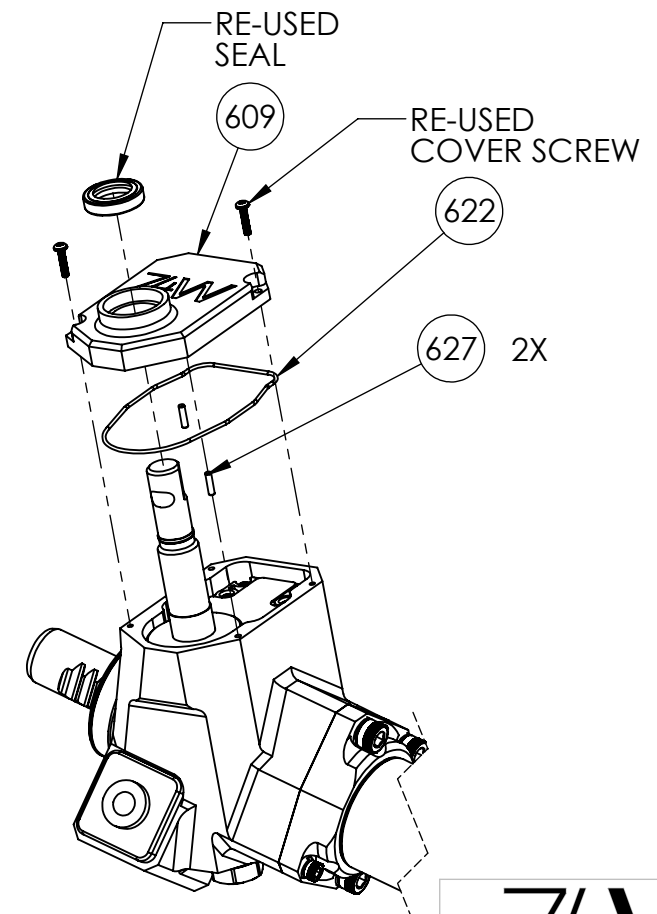

74WELD

SIZE B	DWG. NO. 74W-SR-BRONCO-HOUSING-3.0	REV -
SCALE: 1:4	WEIGHT:	SHEET 8 OF 10

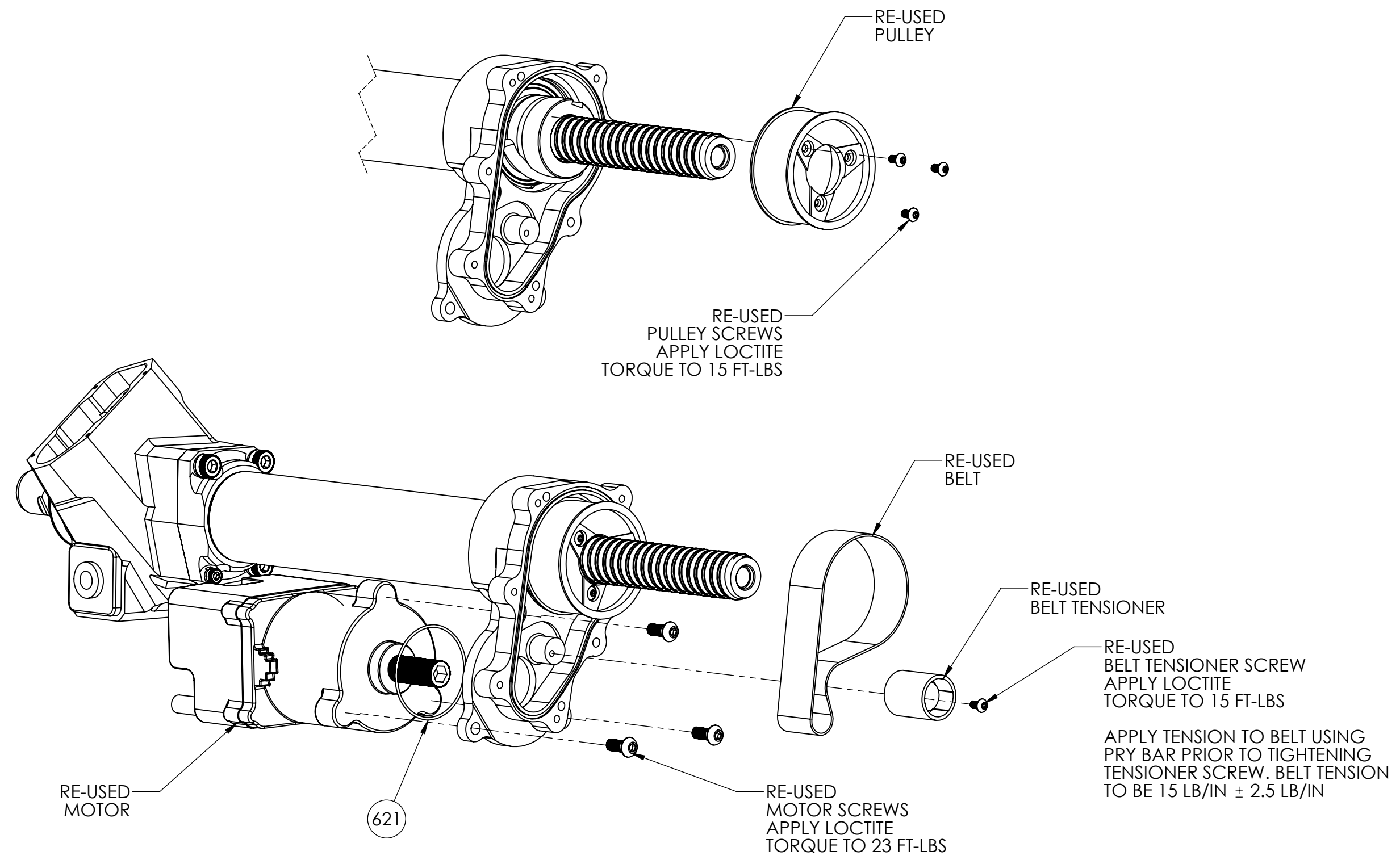

MOTOR SETUP

74WELD		
SIZE B	DWG. NO. 74W-SR-BRONCO- HOUSING-3.0	REV -
SCALE: 1:3	WEIGHT:	SHEET 9 OF 10

8 7 6 5 4 3 2 1

D
C
B
A

D
C
B
A

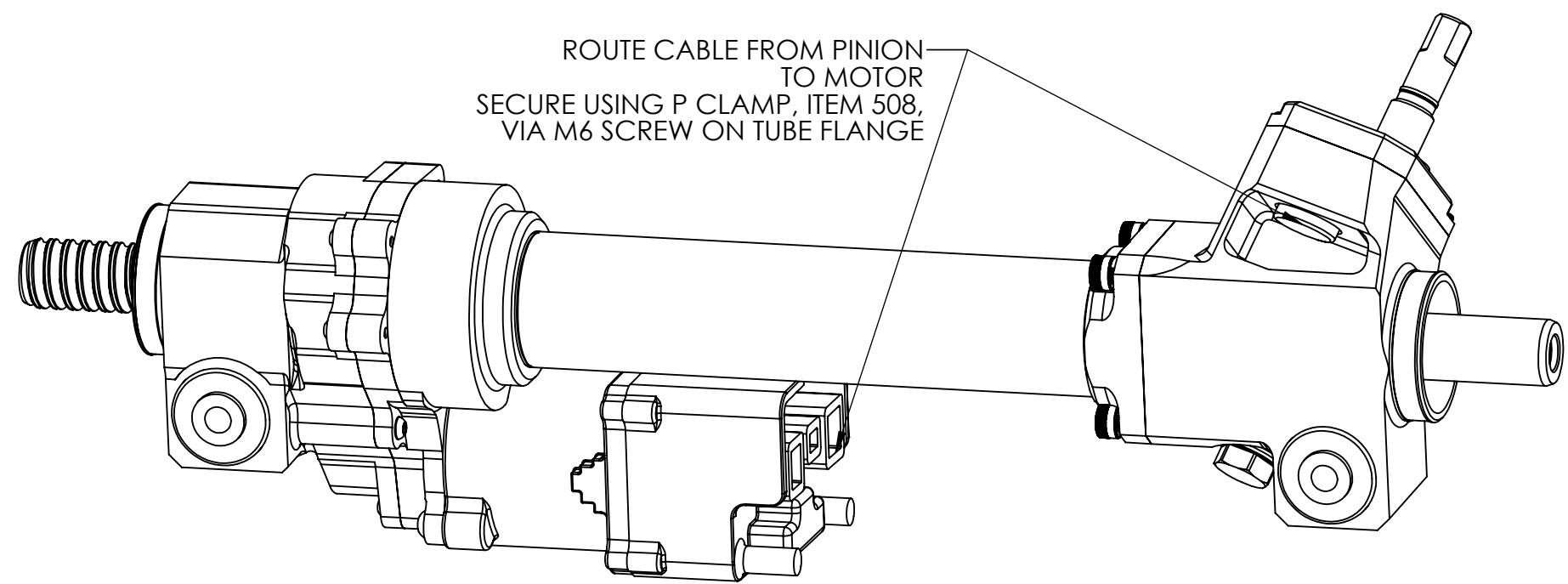
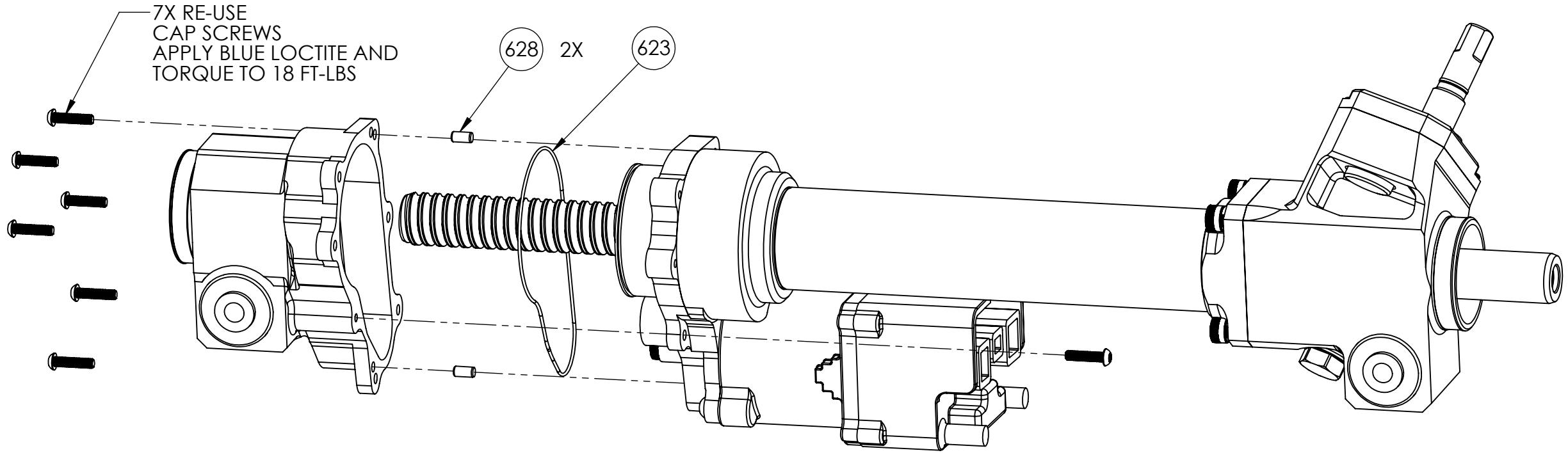

BAG AND TAG QTY (2) HOSE CLAMP, ITEM 634,
TO BE INSTALLED ON VEHICLE

CAP INSTALL

74WELD		
SIZE B	DWG. NO. 74W-SR-BRONCO- HOUSING-3.0	REV -
SCALE: 1:3	WEIGHT:	SHEET 10 OF 10

8 7 6 5 4 3 2 1